

LBU-II

Outdoor loadbreak cutout



Product features

- 7.8/15 kV, 15 kV, 15/27 kV, 20/34.5 kV, and 27 kV
- 110, 125, 150, and 170 kV BIL
- 100 A, 200 A fused
- 300 A disconnect blade
- Porcelain, polymer concrete, or silicone insulators available
- Cutout/arrester combo

Description

The LBU-II cutout performs as an outdoor loadbreak switch, as well as a fused cutout for distribution systems. Loadbreak interruption is accomplished by means of a self-contained loadbreak arc chute which confines the arc and provides a deionizing action.

Conventional operation loadbreak is accomplished by normal opening of the cutout by a hookstick. There are no parts to replace and the loadbreak feature lasts the life of the cutout. The self-contained loadbreak concept enables the line worker to interrupt load current with a simple hook-stick operation. Silicone or polymer concrete insulators and cutout/arrester combinations are available on certain models.

The LBU-II can successfully switch currents as high as 300 A at 15 kV and 50 A at 27 kV. It has fault-

LBU-II loadbreak cutouts are used on overhead distribution systems to provide overcurrent protection, visible indication of fuse operation, and outdoor loadbreak switching.

interrupting (not loadbreak) capacities as high as 20,000 A RMS asymmetrical.

Capacitor banks

The LBU-II provides over-current protection for capacitor banks and gives visible indication that the equipment is de-energized. It also provides a convenient and inexpensive switch capable of interrupting capacitor currents.

Transformer bank switching

The LBU-II can be used for switching the magnetizing currents of both single-phase and three-phase transformer banks.

Sectionalizing

The LBU-II provides a convenient method of sectionalizing single and three-phase, loop, or lateral lines during maintenance or under contingency conditions.

Riser pole

The LBU-II provides a way to switch the capacitive currents associated with the underground feeder cables at the riser pole.

Standards and design testing

The LBU-II cutout meets or exceeds all applicable requirements of EEI, NEMA SG-2, and IEEE C37.41 and C37.42 standards.

Silicone rubber

Utilized for more than 30 years as an outdoor insulation material, silicone rubber is the most commonly used polymeric material for medium and high voltage outdoor insulation. Silicone is used for its superior performance, durability, and insulation properties. It has the unique ability to maintain its hydrophobicity and offers greater stability against heat and ultraviolet radiation compared to other polymers. In addition, silicone cutouts are 30% - 50% lighter than porcelain units.

Polymer concrete

Available in 110 and 125 kV BIL ratings, polymer concrete provides a safe, shatter-proof design with molded-in rods to prevent moisture penetration. Because it resists damage from freeze/thaw cycles, the material is an excellent alternative to porcelain in colder climates. Polymer concrete is a field-proven material that provides excellent electrical properties and dielectric strengths, as well as superior mechanical durability.

Arrester combinations

ABB offers a combination LBU-II cutout with an arrester option. This combination unit is pre-assembled at the factory and provides overall savings by reducing installation time and accumulated costs that result from independently purchased parts.

LBU-II combination units are available with various mounting brackets to fulfill industry requirements. The combo units are equipped with normal duty, heavy duty, and riser pole duty polymer metal oxide arresters.

Fuse tube construction

The LBU-II cutouts utilize two different types of fuse tubes: a moisture-proof fuse tube or a high-strength glass fuse tube. The moisture-proof fuse tube is available on most 100 A designs and reduces swelling that can create problems with interruption.

The 200 A design utilizes a high-strength glass fuse tube. This fuse tube is composed of a horn fiber liner surrounded by a glass filament wound outer shell. Both designs have a durable tube that can withstand the rigors of high fault current interruptions. In addition, the tube is applied with electrostatic powder paint to provide protection against the effects of ultraviolet rays.

Voltage levels

Single voltage rated cutouts can be applied on any single or three-phase system where the line-to-line voltage does not exceed the cutout rating. Dual voltage rated cutouts are suitable on single-phase circuits where maximum line-to-ground voltage does not exceed the value shown to the left of the slash (for example, does not exceed 15 kV in 15/27kV).

LBU-II cutouts may be used on three-phase circuits that are solidly grounded and the maximum line-to-line voltage does not exceed the value shown to the right of the slash (for example, does not exceed 27 kV in 15/27 kV).

Unit dimensions

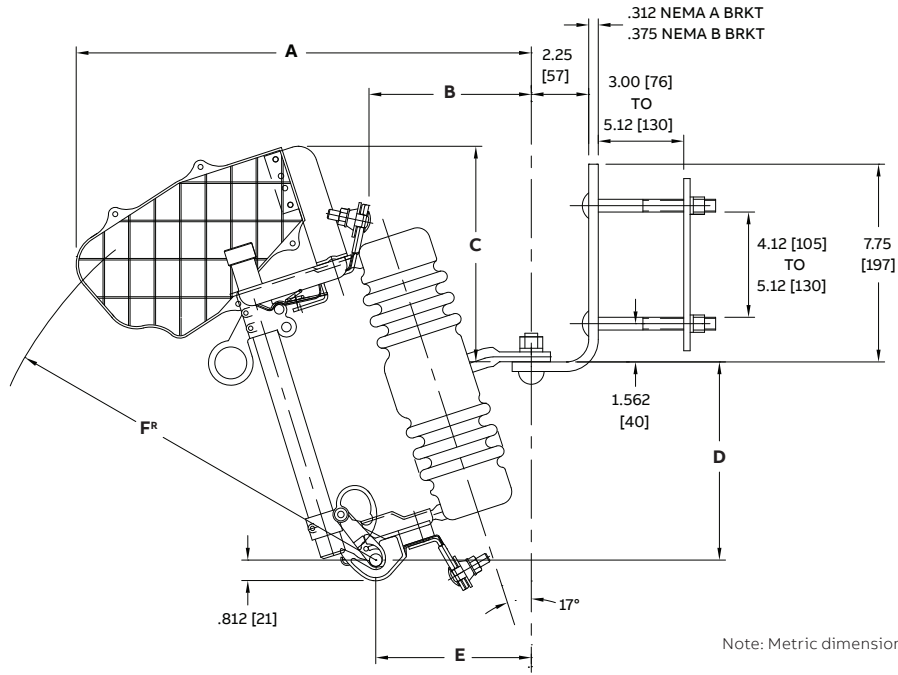

kV Class	BIL (kV)	Unit dimensions (in)						Creep (in)		Weight (lb)	
		A	B	C	D	E	F ^R	Porcelain	Silicone	Porcelain	Silicone
7.8/15 or 15	110	17.75	6.88	8.63	7.84	6.03	15.88	9.10	14.96	13.04	10.14
15/27 or 27.	125	18.50	7.06	10.63	9.44	5.31	19.50	12.80	18.90	16.50	10.98
15/27 or 27.	150	18.50	7.06	10.63	9.44	5.31	19.50	18.00	18.90	24.28	11.08
20/34.5	150	18.50	7.06	10.63	9.44	5.31	19.50	18.00	18.90	24.28	11.08
27	170	18.90	7.20	13.08	11.62	5.50	21.50	26.00	-	18.60	-

kV Class	BIL (kV)	Unit dimensions (mm)						Creep (mm)		Weight (kg)	
		A	B	C	D	E	F ^R	Porcelain	Silicone	Porcelain	Silicone
7.8/15 or 15	110	450.85	174.75	219.20	199.14	153.16	403.35	231.14	379.98	5.91	4.60
15/27 or 27.	125	469.90	179.32	270.00	239.78	134.87	495.30	325.12	480.06	7.48	4.98
15/27 or 27.	150	469.90	179.32	270.00	239.78	134.87	495.30	457.20	480.06	11.01	5.03
20/34.5	150	469.90	179.32	270.00	239.78	134.87	495.30	457.20	480.06	11.01	5.03
27	170	480.06	182.88	332.23	295.15	139.70	546.10	660.40	-	8.44	-

Bracket dimensions

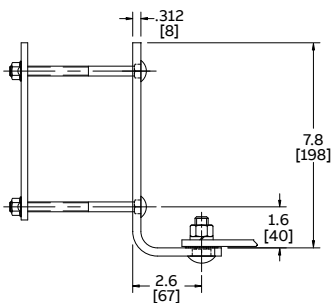

NEMA A bracket

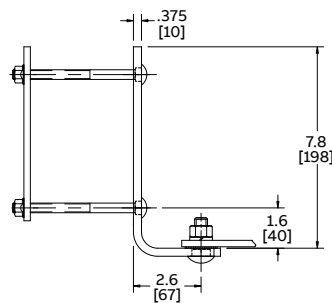

NEMA B bracket

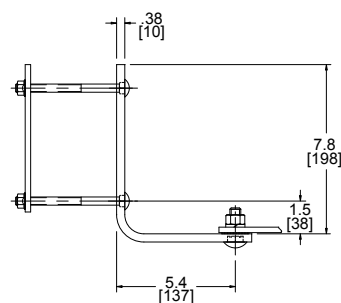

Extended bracket

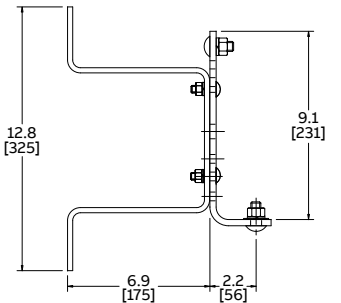

Pole mounting bracket

Ordering instructions for LBU-II cutouts

7.8/15 kV and 15 kV LBU-II

Digit	Description	Code	Definition
1	LBU-II cutout	Y	7.8/15 kV and 15 kV
2	Insulator BIL	1	110 kV BIL
		N	Porcelain
		J	Silicone
3	Fuse supports	Z	Polymer concrete
		C	Clamshell
		E	Eyebolt
4	Terminal connectors	N	None
		N	No bracket
		A	NEMA A
		B	NEMA B
		L	Extended
5	Bracket	C	Universal Combo
6	Special options	N	None
		AM11	100 A, 12 kAIC, solid cap (rated 7.8/15 kV only)
		NA11	100 A, 20 kAIC, barrel exp. cap (rated 7.8/15 kV only)
		DA21	200 A, 12 kAIC, solid cap (rated 7.8/15 kV only)
		PA21	200 A, 20 kAIC, barrel exp. cap (rated 7.8/15 kV only)
		BM11	100 A, 10 kAIC, solid cap (rated 15 kV)
		QA11	100 A, 16 kAIC, barrel exp. cap (rated 15 kV only)
		EA21	200 A, 8 kAIC, solid cap (rated 15 kV)
		GA21	200 A, 10 kAIC, link extender (rated 15 kV)
		UA21	200 A, 12 kAIC, barrel exp. cap (rated 15 kV only)
		VA31	300 A, solid blade (rated for 7.8/15 kV and 15 kV)
7-10	Fuseholder	0000	Fuse support only (no tube)

—
15/27 kV and 27 kV LBU-II

Digit	Description	Code	Definition
1	LBU-II cutout	Y	15/27 kV and 27 kV
		2	125 kV BIL
		4	150 kV BIL, 600 mm creep (silicone only)
2	Insulator BIL	5	150 kV BIL
		N	Porcelain
		J	Silicone
3	Fuse supports	Z	Polymer concrete (110 kV and 125 kV BIL only)
		C	Clamshell
		E	Eyebolt
4	Terminal connectors	N	None
		N	No bracket
		B	NEMA B
5	Bracket	L	Extended
		C	Universal combo
		N	None
6	Special options	V	125 kV silicone insulator for CSA (rated 27 kV, 125 kV BIL, silicone only)
		BM12	100 A, 10 kAIC, solid cap (rated 15/27 kV only)
		QA12	100 A, 16 kAIC, barrel exp. cap (rated 15/27 kV only)
		FA22	200 A, 10 kAIC, solid cap (rated 15/27 kV only)
		HA22	200 A, 16 kAIC, link extender (rated 15/27 kV only)
		CM12	100 A, 6 kAIC, solid cap (rated 27 kV)
		SA12	100 A, 12 kAIC, barrel exp. cap (rated 27 kV)
		KM12	100 A, 12 kAIC, link extender (rated 27 kV)
		VA32	300 A, solid blade (rated 15/27 kV and 27 kV)
7-10	Fuseholder	0000	Fuse support only (no tube)

—
20/34.5 kV LBU-II

Digit	Description	Code	Definition
1	LBU-II cutout	Y	20/34.5 kV
		4	150 kV BIL, 600 mm creep (silicone only)
2	Insulator BIL	5	150 kV BIL
		N	Porcelain
3	Fuse supports	J	Silicone
		C	Clamshell
		E	Eyebolt
4	Terminal connectors	N	None
		N	No bracket
		B	NEMA B
5	Bracket	L	Extended
		C	Universal Combo
6	Special options	N	None
		CM12	100 A, 6 kAIC, solid cap
		TA12	100 A, 12 kAIC, barrel exp. cap
		KM12	100 A, 12 kAIC, link extender
		VA32	300 A, solid blade (rated 15/27 kV and 27 kV)
7-10	Fuseholder	0000	Fuse support only (no tube)

LBU-II cutout arrester combination

Digit	Description	Code	Definition		
1	LBU cutout arrester combination	L	Combo		
		1	15 kV		
		2	27 kV		
		8	15/27 kV		
2	Voltage level	9	20/34.5 kV		
		1	110 kV BIL		
		2	125 kV BIL		
3	Insulator BIL	5	150 kV BIL		
		S	100 A solid cap		
		B	100 A barrel exp. cap		
		L	100 A link extender (only for 27 kV or 20/34.5 kV units)		
		T	200 A solid cap		
4	Cutout cap	C	200 A barrel exp. cap		
		A	Short combo		
5	Bracket	U	Long combo (contact factory for other options)		
		C	Polymer normal duty		
		H	Polymer heavy duty		
6	Arrester type	R	Polymer riser pole		
		03	3 kV		
		06	6 kV		
		09	9 kV		
		10	10 kV		
		12	12 kV		
		15	15 kV		
		18	18 kV		
		21	21 kV		
		24	24 kV		
		7-8	Arrester voltage	27	27 kV
				1	Clamshell
		9	Cutout terminals	2	Eyebolt
1	None				
8	12" lead				
B	Arrester bird guard				
10	Special options	X	No arrester but in combo box		
		Blank	Porcelain		
		J	Silicone		
11	Cutout insulator material	Z	Polymer concrete (110 kV and 125 kV BIL only)		

—
Optional parts and accessories

Replacement fuseholders

Style number	Voltage rating (kV)	BIL (kV)	Current rating (A)	Loadbreak current (A)	Interrupting rating (kA)	Cap type
278C310A03MP	7.8/15	110	100	100	12	Solid
278C310A04	7.8/15	110	100	100	20	Barrel expendable
278C310A05	7.8/15	110	200	200	12	Solid
278C310A06	7.8/15	110	200	200	20	Barrel expendable
278C310A10MP	15	110	100	100	10	Solid
278C310A11	15	110	100	100	16	Barrel expendable
278C310A12	15	110	200	200	8	Solid
278C310A30	15	110	200	200	10	Link extender
278C310A13	15	110	200	200	12	Barrel expendable
278C310A14	15	110	300	300	-	Solid disconnect blade
278C310A17MP	15/27	125 or 150	100	100	10	Solid
278C310A18	15/27	125 or 150	100	100	16	Barrel expendable
278C310A19	15/27	125 or 150	200	200	10	Solid
278C310A48	15/27	125 or 150	200	200	16	Link extender
278C310A21	15/27	125 or 150	300	300	-	Solid disconnect blade
278C310A49MP	15/27	170	100	100	10	Link extender
278C310A50	15/27	170	100	100	10	Barrel expendable
278C310A22MP	20/34.5	150	100	100	6	Solid
278C310A23	20/34.5	150	100	100	12	Barrel expendable
278C310A31MP	20/34.5	150	100	100	12	Link extender
278C310A32MP	20/34.5	170	100	100	12	Link extender
278C310A33	20/34.5	150	300	100	-	Solid disconnect blade
278C310A24MP	27	125 or 150	100	50	6	Solid
278C310A53	27	125 or 150	100	50	12	Barrel expendable
278C310A26MP	27	125 or 150	100	50	12	Link extender
278C310A27MP	27	170	100	50	12	Link extender
278C310A34	27	125 or 150	300	50	-	Solid disconnect blade

Replacement fuseholder caps

Style number	Current rating (A)	Cap type
775H01	100	Solid
162A775H03	200	Solid
3A09870G05	200	Link ext. (110 kV BIL only)
3A09870G01	100	Link ext. (27 kV, 125 or 150 kV BIL only)
3A09870G06	200	Link ext. (15/27 kV, 200 kV BIL only)
3A309870G02	100	Link ext. (15 or 20/34.5 kV, 200 kV BIL only)
3A09870G04	100	Link ext. (27 kV, 200 kV BIL only)
12A00128H01	100	Barrel expendable cap
403A062G03	200	Barrel expendable cap

Brackets

Style number	Type
367C723G05	NEMA A
403A101G03	NEMA B
367C802G05	Extended
791C890G16	Pole mounting

ABB Inc.
3022 NC 43 North
Pinetops, NC 27864
Phone: +1-252-827-3212

We reserve the right to make technical changes or modify the contents of this document without prior notice. With regard to purchase orders, the agreed particulars shall prevail. ABB Inc. does not accept any responsibility whatsoever for potential errors or possible lack of information in this document.

We reserve all rights in this document and in the subject matter and illustrations contained therein. Any reproduction, disclosure to third parties or utilization of its contents—in whole or in parts—is forbidden without prior written consent of ABB Inc. Copyright© 2022 ABB. All rights reserved.